



Pure epoxy mortar anchor, for use in cracked and non-cracked concrete

MOPUR3

ETA assessed Option 1 [cracked and non-cracked concrete].



PRODUCT INFORMATION

DESCRIPTION

Pure epoxy, chemical anchor.

OFFICIAL DOCUMENTATION

- ETA 17/0659 option 1, M8 to M30 for cracked and non-cracked concrete.
- ETA 17/0658 for post-installed rebar installation.
- Declaration features DoP MOPUR3.
- Certificate EVCP 1020-CPR-090-039159 for use in concrete.
- Certificate EVCP 1020-CPD-090-039161 for post-installed rebars.

VALID FOR



Stud



Rebar



Post-installed rebar

DIMENSIONS

Stud M8 - M30

Rebar as stud Ø8 - Ø32

Post-installed rebars Ø8 - Ø32

RANGE OF CALCULATION LOADS

From 12.0 to 157.4 kN [non-cracked].

From 10.7 to 88.0 kN [cracked].

BASE MATERIAL

Concrete quality C20/25 to C50/60 cracked or non-cracked and masonry.



Concrete



Reinforced concrete



Cracked concrete



Thermal clay



Hollow brick

ASSESSMENTS

- ETA 17/0659 [ETAG 001-5] "Option 1: Cracked and non-cracked concrete."
- ETA 17/0658 [TR 023] "Post-installed rebars."

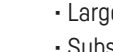

DRILL HOLE CONDITION



Dry



Wet



Flooded

CHARACTERISTICS AND BENEFITS

- Use in cracked and non-cracked concrete.
- Use for very high loads.
- Fire resistance certificate.
- Temperature range -40°C to +70°C (maximum long-term temperature +50°C).
- Variety of lengths and diameters: M8-M30-assessed studs, including M27. Use of rebars as anchor from Ø8 to Ø32, assembly flexibility.
- For static or quasi-static loads and category C1 and C2 seismic applications.
- Approved for use in contact with drinking water.
- Version in zinc plated steel, stainless steel A2 and A4.
- Available in INDEXcal.



MATERIALS

Standard stud:

Carbon steel, zinc plated $\geq 5 \mu\text{m}$.

Stainless standard stud:

Stainless steel A2-70 and A4-70.





APPLICATIONS

- For indoor and outdoor use.
- Structural applications and elements subject to vibrations.
- Rebars and start rebars.
- Applications at high temperature.
- Safety barriers, retaining walls, heavy machinery, etc.
- Large metric sizes, retaining walls.
- Substructure fixing to the building.





CONCRETE INSTALLATION PARAMETERS

METRIC			M8	M10	M12	M16	M20	M24	M27	M30
d_0	nominal diameter	[mm]	10	12	14	18	22	26	30	35
d_f	diameter in anchor plate \leq	[mm]	9	12	14	18	22	26	30	33
T_{inst}	tightening torque \leq	[Nm]	10	20	40	80	120	160	180	200
Circular cleaning brush			$\varnothing 14$		$\varnothing 20$		$\varnothing 29$		$\varnothing 40$	
$h_{ef,min} = 8d$										
h_1	depth of the drill hole	[mm]	60	60	70	80	90	96	108	120
$s_{cr,N}$	critical distance between anchors	[mm]	180	180	210	240	270	288	324	360
$c_{cr,N}$	critical distance from the edge	[mm]	90	90	105	120	135	144	162	180
c_{min}	minimum distance from the edge	[mm]	40	40	40	40	50	50	50	50
s_{min}	minimum distance between anchors	[mm]	40	40	40	40	50	50	50	50
h_{min}	minimum concrete thickness	[mm]	100	100	105	120	135	150	170	185
Standard stud										
h_1	depth of the drill hole	[mm]	80	90	110	128	170	210	-	280
$s_{cr,N}$	critical distance between anchors	[mm]	240	270	330	384	510	630	-	840
$c_{cr,N}$	critical distance from the edge	[mm]	120	135	165	192	255	315	-	420
c_{min}	minimum distance from the edge	[mm]	43	45	56	65	85	105	-	140
s_{min}	minimum distance between anchors	[mm]	43	45	56	65	85	105	-	140
h_{min}	minimum concrete thickness	[mm]	115	125	145	165	215	263	-	345
$h_{ef,max} = 20d$										
h_1	depth of the drill hole	[mm]	160	200	240	320	400	480	540	600
$s_{cr,N}$	critical distance between anchors	[mm]	480	600	720	960	1200	1440	1620	1800
$c_{cr,N}$	critical distance from the edge	[mm]	240	300	360	480	600	720	810	900
c_{min}	minimum distance from the edge	[mm]	80	100	120	160	200	240	270	300
s_{min}	minimum distance between anchors	[mm]	80	100	120	160	200	240	270	300
h_{min}	minimum concrete thickness	[mm]	195	235	275	360	445	535	600	665
Zinc-plated stud code										
			EQAC08110	EQAC10130	EQAC12160	EQAC16190	EQAC20260	EQAC24300	-	EQAC30330
Stainless steel stud code A2 / A4										
			EQA208110 EQA408110	EQA210130 EQA410130	EQA212160 EQA412160	EQA216190 EQA416190	EQA220260 EQA420260	EQA224300 EQA424300	-	EQA230330 EQA430330

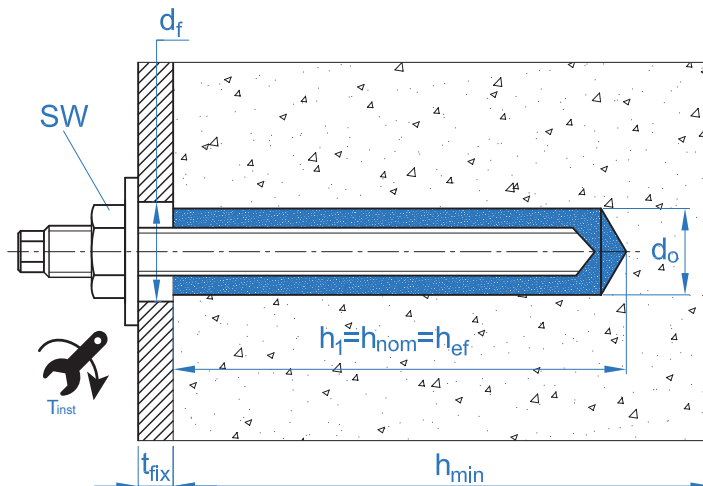



INSTALLATION ACCESSORIES			INSTALLATION PROCEDURE
CODE	PRODUCT	MATERIAL	CONCRETE
MOPISSI	APPLICATION GUNS	Gun for 300 ml cartridges	
MOPISTO		Guns for 410 ml cartridges, professional use	
MOPISENU		Pneumatic gun for 410 ml coaxial cartridges, professional use	
EQ-AC EQ-A2 EQ-A4	STUD	Studs threaded steel, class 5.8 ISO 898-1 Studs stainless steel A2-70 Studs stainless steel A4-70	
MORCEPKIT	CLEANING BRUSHES	Kit with 3 cleaning brushes measuring $\varnothing 14$, $\varnothing 20$ and $\varnothing 29$ mm	
MOBOMBA	CLEANING PUMP	Pump for cleaning leftover dust and fragments in the drill hole	
MORCANU	MIXING TUBE	Plastic. Static labyrinth mixture	

MINIMUM CURING TIME			
TYPE	BASE MATERIAL TEMPERATURE [°C]	HANDLING TIME [min]	CURING TIME [heures]
MOPUR3	+5	300	24
	+5 to +10	150	24
	+10 to +15	40	18
	+15 to +20	25	12
	+20 to +25	18	8
	+25 to +30	12	6
	+30 to +35	8	4
	+35 to +40	6	2



Resistance in concrete C20/25 for an insulated anchor, without effects of distance from the edge or spacing between anchors, with a standard stud EQ-AC, EQ-A2 or EQ-A4.

Characteristic tensile strength N_{Rk}										
Metric			M8	M10	M12	M16	M20	M24	M27	M30
N_{Rk}	Non-cracked concrete	[kN]	<u>18.0</u>	<u>29.0</u>	<u>42.0</u>	73,0*	111,7*	153,4*	-	236,1*
	Cracked concrete	[kN]	16.1	22.6	31.1	48.3	74.8	110.8	-	131.9
Calculated tensile strength N_{Rd}										
Metric			M8	M10	M12	M16	M20	M24	M27	M30
N_{Rd}	Non-cracked concrete	[kN]	<u>12.0</u>	<u>19.3</u>	<u>28.0</u>	48,7*	74,5*	102,3*	-	157,4*
	Cracked concrete	[kN]	10.7	15.1	20.7	32.2	49.8	73.9	-	88.0
Maximum recommended tensile load N_{rec}										
Metric			M8	M10	M12	M16	M20	M24	M27	M30
N_{rec}	Non-cracked concrete	[kN]	<u>8.6</u>	<u>13.8</u>	<u>20.0</u>	34,8*	53,2*	73,0*	-	112,4*
	Cracked concrete	[kN]	7.7	10.8	14.8	23.0	35.6	52.8	-	62.8
Characteristic resistance to shear stress V_{Rk}										
Metric			M8	M10	M12	M16	M20	M24	M27	M30
V_{Rk}	Zinc-plated stud	[kN]	<u>9.0</u>	<u>15.0</u>	<u>21.0</u>	<u>39.0</u>	<u>61.0</u>	<u>88.0</u>	<u>115.0</u>	<u>140.0</u>
	Stainless steel stud (A2/A4)	[kN]	<u>13.0</u>	<u>20.0</u>	<u>30.0</u>	<u>55.0</u>	<u>86.0</u>	<u>124.0</u>	<u>161.0</u>	<u>196.0</u>
Calculated resistance to shearing V_{Rd}										
Metric			M8	M10	M12	M16	M20	M24	M27	M30
V_{Rd}	Zinc-plated stud	[kN]	<u>7.2</u>	<u>12.0</u>	<u>16.8</u>	<u>31.2</u>	<u>48.8</u>	<u>70.4</u>	<u>92.0</u>	<u>112.0</u>
	Stainless steel stud (A2/A4)	[kN]	<u>8.3</u>	<u>12.8</u>	<u>19.2</u>	<u>35.3</u>	<u>55.1</u>	<u>79.5</u>	<u>103.2</u>	<u>125.6</u>
Maximum recommended load to shear stress V_{rec}										
Metric			M8	M10	M12	M16	M20	M24	M27	M30
V_{rec}	Zinc-plated stud	[kN]	<u>5.1</u>	<u>8.6</u>	<u>12.0</u>	<u>22.3</u>	<u>34.9</u>	<u>50.3</u>	<u>65.7</u>	<u>80.0</u>
	Stainless steel stud (A2/A4)	[kN]	<u>6.0</u>	<u>9.2</u>	<u>13.7</u>	<u>25.2</u>	<u>39.4</u>	<u>56.8</u>	<u>73.7</u>	<u>89.7</u>
Effective depth of studs EQ-AC / EQ-A2 / EQ-A4										
Metric			M8	M10	M12	M16	M20	M24	M27	M30
Effective depth		[mm]	80	90	110	128	170	210	-	280

The values underlined and in italics indicate steel failure. * The highlighted values indicate concrete failure.

Simplified calculation method. European Technical Assessment ETA 14/0138

Simplified version of the calculation method according to ETAG 001, technical report TR029. The resistance is calculated according to the data reflected in ETA assessment 14/0138.

The calculation method is based on the following simplification:
No different loads act on individual anchors, without eccentricity.

- Influence of concrete resistance.
- Influence of the distance from the edge of the concrete.
- Influence of the spacing between anchors.
- Influence of rebars.
- Influence of the base material thickness.
- Influence of the load application angle.
- Influence of the effective depth.
- Valid for a group of two anchors.
- Valid for dry or wet drill holes.



INDEXcal

For a more precise calculation and taking into account more constructive arrangements we recommend the use of our INDEXcal calculation program. It can be downloaded free from our website www.indexfix.com



TENSILE LOADS

- Calculated steel resistance: $N_{Rd,s}$
- Calculated extraction resistance: $N_{Rd,p} = N_{Rd,p}^o \cdot \psi_c \cdot \psi_{hef,p}$
- Calculated concrete cone resistance: $N_{Rd,c} = N_{Rd,c}^o \cdot \psi_b \cdot \psi_{s,N} \cdot \psi_{c,N} \cdot \psi_{re,N} \cdot \psi_{hef,N}$
- Calculated concrete cracking resistance: $N_{Rd,sp} = N_{Rd,c}^o \cdot \psi_b \cdot \psi_{s,sp} \cdot \psi_{c,sp} \cdot \psi_{re,N} \cdot \psi_{h,sp} \cdot \psi_{hef,N}$

MOPUR3

Calculated steel resistance										
$N_{Rd,s}$										
Metric		M8	M10	M12	M16	M20	M24	M27	M30	
$N_{Rd,s}^o$	Steel class 4.6	[kN]	7.5	11.5	17	31.5	49	70.5	92	112
	Steel class 5.8	[kN]	12	19.3	28	52.7	82	118	153.3	187.3
	Steel class 8.8	[kN]	19.3	30.7	44.7	84	130.7	188	244.7	299.3
	Steel class 10.9	[kN]	27.8	43.6	63.2	118	184.2	265.4	345.1	421.8
	Stainless steel class A2-70, A4-70	[kN]	13.9	21.9	31.6	58.8	92	132.1	171.7	210.2

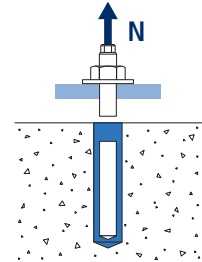

Calculated extraction resistance										
$N_{Rd,p} = N_{Rd,p}^o \cdot \psi_c \cdot \psi_{hef,p}$										
Metric		M8	M10	M12	M16	M20	M24	M27	M30	
$N_{Rd,p}^o$	Non-cracked concrete	[kN]	18.8	24.5	35.9	51.5	85.5	116.1	137.4	158.3
	Cracked concrete	[kN]	-	15.1	20.7	32.2	49.8	73.9	-	-

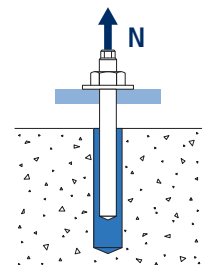

Calculated concrete cone resistance										
$N_{Rd,c} = N_{Rd,c}^o \cdot \psi_b \cdot \psi_{s,N} \cdot \psi_{c,N} \cdot \psi_{re,N} \cdot \psi_{hef,N}$										
Metric		M8	M10	M12	M16	M20	M24	M27	M30	
$N_{Rd,c}^o$	Non-cracked concrete	[kN]	24.1	28.7	38.8	48.8	74.6	102.5	127.5	157.7
	Cracked concrete	[kN]	17.2	20.5	27.7	34.8	53.2	73.0	90.9	112.4

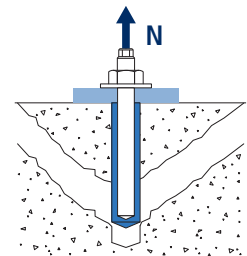

Calculated concrete cracking resistance										
$N_{Rd,sp} = N_{Rd,c}^o \cdot \psi_b \cdot \psi_{s,sp} \cdot \psi_{c,sp} \cdot \psi_{re,N} \cdot \psi_{h,sp} \cdot \psi_{hef,N}$										
Metric		M8	M10	M12	M16	M20	M24	M27	M30	
$N_{Rd,sp}^o$	Non-cracked concrete	[kN]	24.1	28.7	38.8	48.8	74.6	102.5	127.5	157.7

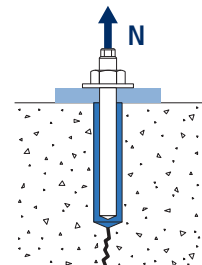



MOPUR3

Influence coefficients

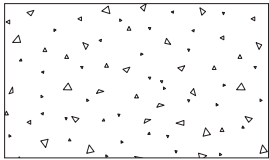

Influence of concrete resistance for extraction Ψ_c					
Concrete type		C20/25	C30/37	C40/50	C50/60
Ψ_c	Non-cracked concrete	1.0			
	Cracked concrete	1.00	1.04	1.07	1.09

$$\Psi_b = \sqrt{\frac{f_{ck,cube}}{25}} \geq 1$$

Influence of concrete resistance for concrete cone and concrete cracking Ψ_b					
Concrete type		C20/25	C30/37	C40/50	C50/60
Ψ_b		1.00	1.22	1.41	1.55

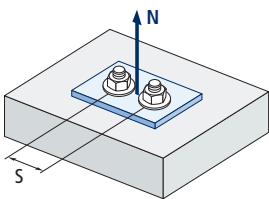

Influence of spacing between anchors (concrete cone) $\Psi_{s,N}$										
$s/s_{cr,N}$	0.1	0.2	0.3	0.4	0.5	0.6	0.7	0.8	0.9	1.0
$\Psi_{s,N}$	0.55	0.60	0.65	0.70	0.75	0.80	0.85	0.90	0.95	1.00

$$\Psi_{s,N} = 0.5 \left(1 + \frac{s}{s_{cr,N}} \right) \leq 1$$

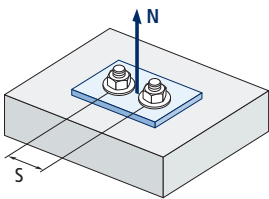

Influence of spacing between anchors (cracking) $\Psi_{s,sp}$										
$s/s_{cr,sp}$	0.1	0.2	0.3	0.4	0.5	0.6	0.7	0.8	0.9	1.0
$\Psi_{s,sp}$	0.55	0.60	0.65	0.70	0.75	0.80	0.85	0.90	0.95	1.00

$$\Psi_{s,sp} = 0.5 \left(1 + \frac{s}{s_{cr,sp}} \right) \leq 1$$

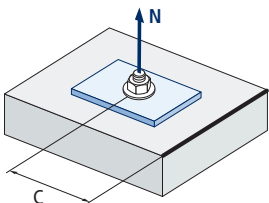

Influence of the distance from the edge of the concrete (concrete cone) $\Psi_{c,N}$												
$c/C_{cr,N}$	0.1	0.2	0.3	0.5	0.6	0.8	0.9	1.1	1.2	1.4	1.5	1.6
$\Psi_{c,N}$	0.40	0.46	0.51	0.45	0.49	0.55	0.61	0.67	0.75	0.83	0.91	1.00

$$\Psi_{c,N} = 0.35 + \frac{0.5 \cdot c}{C_{cr,N}} + \frac{0.15 \cdot c^2}{C_{cr,N}^2} \leq 1$$

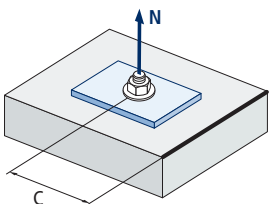

Influence of the distance from the edge of the concrete (cracking) $\Psi_{c,sp}$												
$c/C_{cr,sp}$	0.1	0.2	0.3	0.5	0.6	0.8	0.9	1.1	1.2	1.4	1.5	1.6
$\Psi_{c,sp}$	0.40	0.46	0.51	0.45	0.49	0.55	0.61	0.67	0.75	0.83	0.91	1.00

$$\Psi_{c,sp} = 0.35 + \frac{0.5 \cdot c}{C_{cr,sp}} + \frac{0.15 \cdot c^2}{C_{cr,sp}^2} \leq 1$$

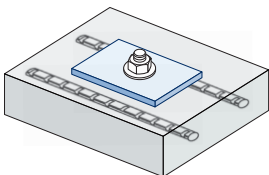

Influence of the rebars $\Psi_{re,N}$					
h_{ef} (mm)	64	70	80	90	100
$\Psi_{re,N}$	0.82	0.85	0.90	0.95	1.00

$$\Psi_{re,N} = 0.5 + \frac{h_{ef}}{200} \leq 1$$

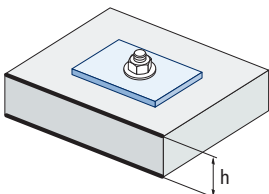

Influence of the base material thickness $\Psi_{h,sp}$											
$\Psi_{h,sp}$	h/h_{ef}	2.00	2.20	2.40	2.60	2.80	3.00	3.20	3.40	3.60	3.68
	fh	1.00	1.07	1.13	1.19	1.25	1.31	1.37	1.42	1.48	1.50

$$\Psi_{h,sp} = \left(\frac{h}{2 \cdot h_{ef}} \right)^{2/3} \leq 1.5$$



MOPUR3

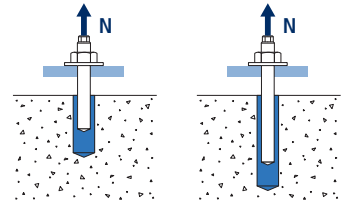

$$\Psi_{\text{hef,p}} = \frac{h_{\text{ef}}}{h_{\text{stand}}}$$

Influence of the effective depth for the extraction combination $\Psi_{\text{hef,p}}$								
Metric h_{ef}	M8	M10	M12	M16	M20	M24	M27	M30
64	0.80							
80	1.00	0.89						
90	1.13	1.00						
96	1.20	1.07	0.87					
110	1.38	1.22	1.00					
128	1.60	1.42	1.16	1.00				
160	2.00	1.78	1.45	1.25	0.94			
170		1.89	1.55	1.33	1.00			
192		2.13	1.75	1.50	1.13	0.91		
200		2.22	1.82	1.56	1.18	0.95		
210			1.91	1.64	1.24	1.00		
216			1.96	1.69	1.27	1.03	0.89	
240			2.18	1.88	1.41	1.14	0.99	0.86
243				1.90	1.43	1.16	1.00	0.87
280				2.19	1.65	1.33	1.15	1.00
320				2.50	1.88	1.52	1.32	1.14
400					2.35	1.90	1.65	1.43
480						2.29	1.98	1.71
540							2.22	1.93
600								2.14

Influence of the effective depth for the concrete cone $\Psi_{\text{hef,N}}$								
Metric h_{ef}	M8	M10	M12	M16	M20	M24	M27	M30
64	0.72							
80	1.00	0.84						
90	1.19	1.00						
96	1.31	1.10	0.82					
110	1.61	1.35	1.00					
128	2.02	1.70	1.26	1.00				
160	2.83	2.37	1.75	1.40	0.91			
170		2.60	1.92	1.53	1.00			
192		3.12	2.31	1.84	1.20	0.87		
200		3.31	2.45	1.95	1.28	0.93		
210			2.64	2.10	1.37	1.00		
216			2.75	2.19	1.43	1.04	0.84	
240			3.22	2.57	1.68	1.22	0.98	0.79
243				2.62	1.71	1.24	1.00	0.81
280				3.24	2.11	1.54	1.24	1.00
320				3.95	2.58	1.88	1.51	1.22
400					3.61	2.63	2.11	1.71
480						3.46	2.78	2.24
540							3.31	2.68
600								3.14

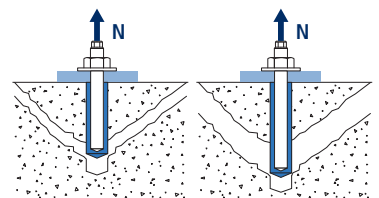

$$\Psi_{\text{hef,N}} = \left(\frac{h_{\text{ef}}}{h_{\text{stand}}} \right)^{1.5}$$



MOPUR3

SHEARING LOADS

- Calculated steel resistance without lever arm: $V_{Rd,s}$
- Calculated spalling resistance: $V_{Rd,cp} = k \cdot N_{Rd,c}^0$
- Calculated concrete edge resistance: $V_{Rd,c} = V_{Rd,c}^0 \cdot \Psi_b \cdot \Psi_{se,V} \cdot \Psi_{c,V} \cdot \Psi_{re,V} \cdot \Psi_{\alpha,V} \cdot \Psi_{h,V}$

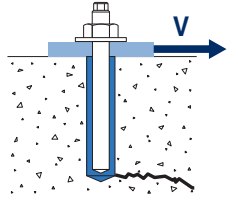
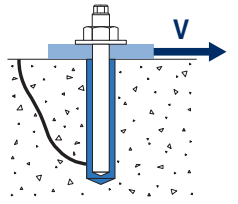
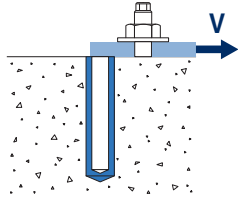

		Calculated steel resistance to shearing								
		$V_{Rd,s}$								
Metric		M8	M10	M12	M16	M20	M24	M27	M30	
$V_{Rd,s}^0$	Steel class 4.6	[kN]	4.2	7.2	10.2	18.6	29.3	42.5	55.1	67.1
	Steel class 5.8	[kN]	7.2	12.0	16.8	31.2	48.8	70.4	92.0	112.0
	Steel class 8.8	[kN]	12.0	18.4	27.2	50.4	78.4	112.8	147.2	179.2
	Steel class 10.9	[kN]	12.0	19.3	28.0	52.7	82.0	118.0	153.3	187.3
	Stainless steel class A2-70, A4-70	[kN]	8.3	12.8	19.2	35.3	55.1	79.5	103.2	125.6

		Calculated spalling resistance							
		$V_{Rd,cp} = k \cdot N_{Rd,c}^0$							
Metric		M8	M10	M12	M16	M20	M24	M27	M30
k		2							

		Calculated concrete edge resistance								
		$V_{Rd,c} = V_{Rd,c}^0 \cdot \Psi_b \cdot \Psi_{se,V} \cdot \Psi_{c,V} \cdot \Psi_{re,V} \cdot \Psi_{\alpha,V} \cdot \Psi_{h,V}$								
Metric		M8	M10	M12	M16	M20	M24	M27	M30	
$V_{Rd,c}^0$	Non-cracked concrete	[kN]	5.7	8.6	11.8	19.0	28.3	36.4	-	55.5
	Cracked concrete	[kN]	4.1	6.1	8.4	13.4	20.1	25.8	-	39.5

Influence coefficients

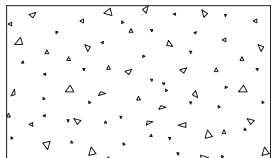

$$\Psi_b = \sqrt{\frac{f_{ck,cube}}{25}} \geq 1$$

Influence of concrete resistance for concrete cone and concrete cracking Ψ_b				
Concrete type	C20/25	C30/37	C40/50	C50/60
Ψ_b	1.00	1.22	1.41	1.55

Influence of the distance from the edge and spacing between anchors $\Psi_{se,V}$																	
For one anchor																	
c/h_{ef}	0.50	0.75	1.00	1.25	1.50	1.75	2.00	2.25	2.50	2.75	3.00	3.25	3.50	3.75	4.00	4.50	5.00
Insulated	0.35	0.65	1.00	1.40	1.84	2.32	2.83	3.38	3.95	4.56	5.20	5.86	6.55	7.26	8.00	9.55	11.18
For two anchors																	
s/c	0.50	0.75	1.00	1.25	1.50	1.75	2.00	2.25	2.50	2.75	3.00	3.25	3.50	3.75	4.00	4.50	5.00
1.0	0.24	0.43	0.67	0.93	1.22	1.54	1.89	2.25	2.64	3.04	3.46	3.91	4.37	4.84	5.33	6.36	7.45
1.5	0.27	0.49	0.75	1.05	1.38	1.74	2.12	2.53	2.96	3.42	3.90	4.39	4.91	5.45	6.00	7.16	8.39
2.0	0.29	0.54	0.83	1.16	1.53	1.93	2.36	2.81	3.29	3.80	4.33	4.88	5.46	6.05	6.67	7.95	9.32
2.5	0.32	0.60	0.92	1.28	1.68	2.12	2.59	3.09	3.62	4.18	4.76	5.37	6.00	6.66	7.33	8.75	10.25
≥ 3.0	0.35	0.65	1.00	1.40	1.84	2.32	2.83	3.38	3.95	4.56	5.20	5.86	6.55	7.26	8.00	9.55	11.18

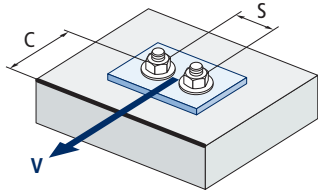
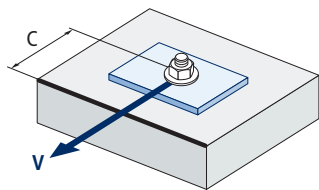

$$\Psi_{se,V} = \left(\frac{c}{h_{ef}}\right)^{1.5}$$

$$\Psi_{se,V} = \left(\frac{c}{h_{ef}}\right)^{1.5} \cdot \left(1 + \frac{s}{3 \cdot c}\right) \cdot 0.5 \leq \left(\frac{c}{h_{ef}}\right)^{1.5}$$



MOPUR3

Influence of the distance from the edge of the concrete $\Psi_{c,v}$

c/d	4	5	7	10	15	20	25	30
-----	---	---	---	----	----	----	----	----

$\Psi_{c,v}$	0.76	0.72	0.68	0.63	0.58	0.55	0.53	0.51
--------------	------	------	------	------	------	------	------	------

$$\Psi_{c,v} = \left(\frac{d}{c}\right)^{0.20}$$

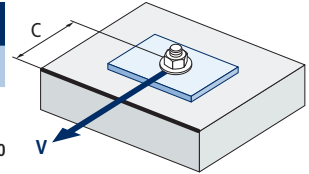

Influence of the effective depth $\Psi_{hef,v}$

h_{ef}/d	8	9	10	11	12	13	14	15	16	17	18	19	20
------------	---	---	----	----	----	----	----	----	----	----	----	----	----

$\Psi_{hef,v}$	1.65	2.04	2.47	2.93	3.42	3.94	4.50	5.10	5.72	6.38	7.06	7.78	8.53
----------------	------	------	------	------	------	------	------	------	------	------	------	------	------

$$\Psi_{hef,v} = 0.04 \cdot \left(\frac{h_{ef}}{d}\right)^{1.79}$$

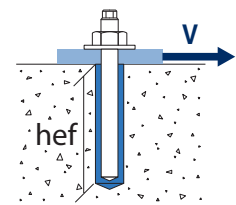

Influence of the rebars $\Psi_{re,v}$

		Without perimeter rebar	Perimeter rebar $\geq \varnothing 12\text{mm}$	Perimeter rebar with abutments at $\leq 100\text{mm}$
$\Psi_{re,v}$	Non-cracked concrete	1	1	1
	Cracked concrete	1	1.2	1.4

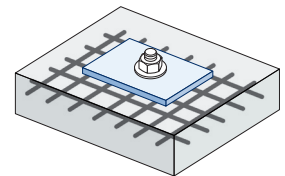

Influence of the load application angle $\Psi_{\alpha,v}$

Angle, $\alpha(^{\circ})$	0°	10°	20°	30°	40°	50°	60°	70°	80°	90°
---------------------------	----	-----	-----	-----	-----	-----	-----	-----	-----	-----

$\Psi_{\alpha,v}$	1.00	1.01	1.05	1.13	1.24	1.40	1.64	1.97	2.32	2.50
-------------------	------	------	------	------	------	------	------	------	------	------

$$\Psi_{\alpha,v} = \sqrt{\frac{1}{(\cos \alpha_v)^2 + \left(\frac{\sin \alpha_v}{2.5}\right)^2}} \geq 1$$

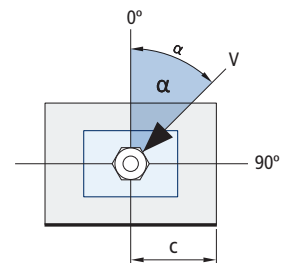

Influence of the base material thickness $\Psi_{h,v}$

h/c	0.15	0.30	0.45	0.60	0.75	0.90	1.05	1.20	1.35	≥ 1.5
-----	------	------	------	------	------	------	------	------	------	------------

$\Psi_{h,v}$	0.32	0.45	0.55	0.63	0.71	0.77	0.84	0.89	0.95	1.00
--------------	------	------	------	------	------	------	------	------	------	------

$$\Psi_{h,v} = \left(\frac{h}{1.5 \cdot c}\right)^{0.5} \geq 1.0$$

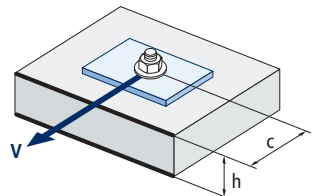

MOPUR3

RETROFITTED REBAR CONNECTIONS

This technical document covers post-installed rebar connections in non-carbonate concrete under the assumption that post-installed rebar connections are generally calculated according to Eurocode 2. The rebar anchor system comprises the bonding of the material and a straight, recessed reinforcement rebar with the properties specified in Eurocode 2, Annex C; classes B and C.

Dynamic, fatigue or seismic loads on post-installed rebar connections are not covered by this technical document.

Intended use

This technical document covers application in non-carbonate concrete only from C12/15 to C50/60 (EN 206) for the following applications:

- Overlapping bond with an existing rebar in a building component (Figures 1 and 4).
- Fixing of rebar in a slab or in a support. Support at one end of a slab calculated as simply supported as well as its rebars for retention forces (Figure 2).
- Fixing of rebar of construction components mainly subjected to compression (Figure 3).
- Fixing of rebar to cover the action line of the tensile force (Figure 5).

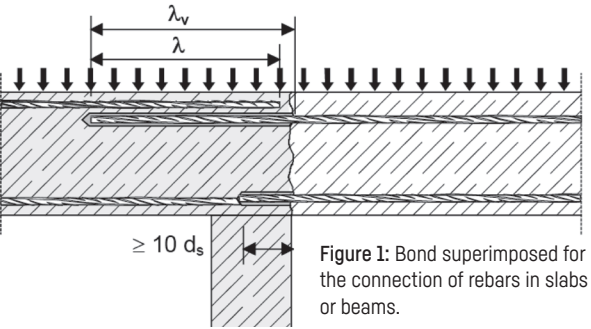

Figure 1: Bond superimposed for the connection of rebars in slabs or beams.

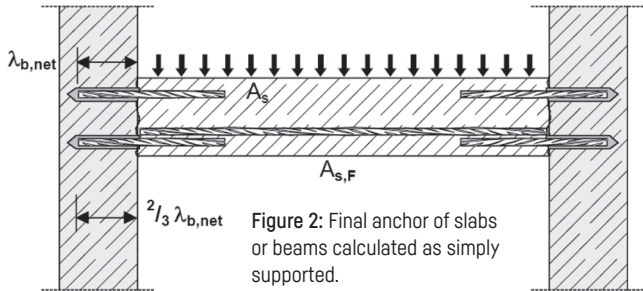

Figure 2: Final anchor of slabs or beams calculated as simply supported.

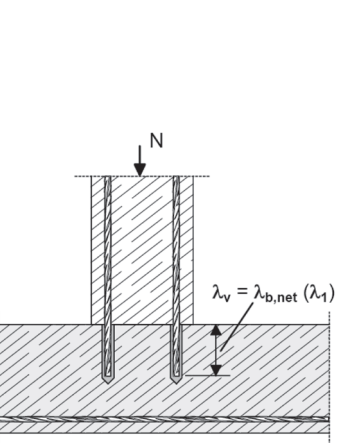

Figure 3: Rebar connections for items primarily subjected to compression. The rebars are subjected to compression.

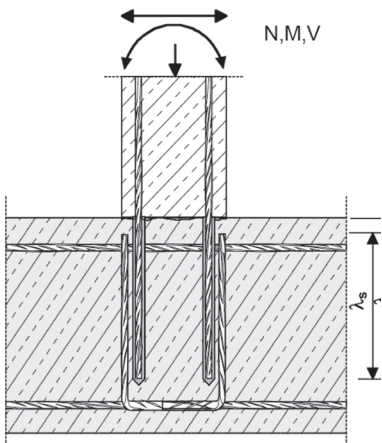

Figure 4: Bond superimposed to a foundation of a column or a wall where the rebars is subjected to tensile force.

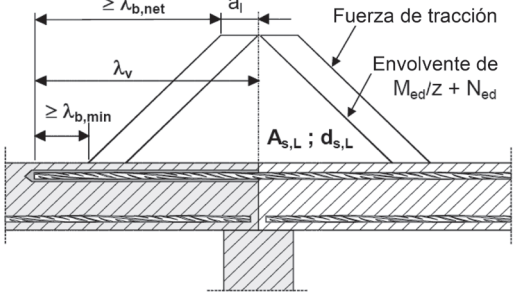

Figure 5: Reinforcement anchor to cover the action line of the tensile force.

* Note for Figure 1 and 5: In the figures the transversal reinforcements have not been represented, the transversal reinforcements as required by the Eurocode 2 must be present. The shear stress transferred between the anterior and posterior concrete must be calculated according to Eurocode 2.

**MOPUR3**

The tables shown below refer to Eurocode 2 Annex C, Table C.1 and C2N, rebar properties.

Properties of the start rebars				
Product form		Rebars and unwound rods		
Class		B	C	
Characteristic yield stress f_{yk} or $f_{0.2k}$ (MPa)		400 to 600		
Minimum value of $k = (f_t / f_{yk})_k$		≥ 1.08	≥ 1.15	
Characteristic maximum tensile deformation ϵ_{uk} (%)		≥ 5.0	< 1.35	
Flexibility		Bending/folding test		
Maximum deviation from the nominal weight (individual bar or wire) (%)	Nominal size of the rebar (mm) $\leq 8 > 8$	± 6.0		
		± 4.5		
Bonding: Minimum relative corrugated area, $f_{R,min}$	Nominal size of the rebar (mm) 8 to 12 > 12	0.040		
		0.056		

Minimum / maximum installation length ℓ_{max}				
Corrugated bars		Minimum		Maximum
		Anchor $\ell_{b,min}$	Overlapped connection $\ell_{o,min}$	ℓ_{max}
$\varnothing d_s$ [mm]	$f_{y,k}$ [N/mm ²]	[mm]	[mm]	[mm]
8	500	113	200	400
10	500	142	200	500
12	500	170	200	600
14	500	198	210	700
16	500	227	240	800
20	500	284	300	1000
25	500	354	375	1000
28	500	397	420	1000
32	500	454	480	1000

Calculated bonding resistance [N/mm ²] f_{bd}									
Bar \varnothing d_s [mm]	Concrete class								
	C12/15	C16/20	C20/25	C25/30	C30/37	C35/45	C40/50	C45/55	C50/60
8 to 28	1.6	2.0	2.3	2.7	3.0	3.4	3.7	4.0	4.3
32								3.7	

$$N = f_{bd} \cdot \Phi \cdot L_b \cdot \pi$$



MOPUR3

Calculated load values according to Eurocode 2 and EOTA technical report TR 023.

- Information according to ETA 17/0658.
- Non-cracked concrete, conditions in dry or wet conditions.
- Temperature range: -40°C to +80°C [maximum long-term temperature +50°C].
- Minimum spacing conditions between bars $\geq 5d_s$, min. 50 mm:

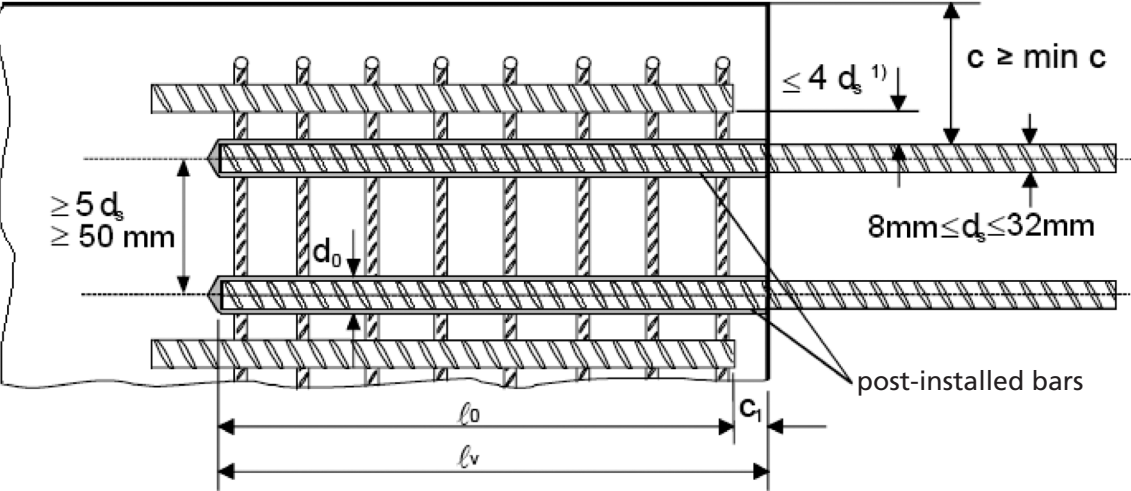

- Minimum concrete coating:
 - drilling with compressed air $\geq 50 + 0.06 L_b$
 - drilling in percussion mode $\geq 30 + 0.08 L_b \geq 2\Phi$
- Good bonding conditions:

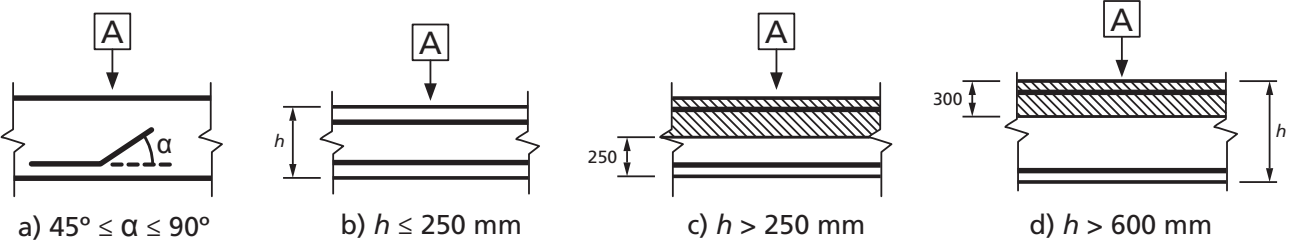

A Direction of the concreting (a) and (b) "good" bonding conditions for all types of bars. (c) and (d) without shaded area - "good" bonding conditions. Shaded area- "poor" bonding conditions.

* In case of poor bonding conditions, multiply values by 0.7.



MOPUR3

Resistance values may increase in the following situations:

- With transverse tension/compression pressure (α_2)
- In case of concrete coating (α_5)
- In case of overlapping rebars (α_6)

Values for α_2 , α_5 and α_6		
Influence factor	Reinforcement bar	
	A tension	A compression
Concrete coating	$\alpha_2 = 1 - 0.15 (cd - \emptyset) / \emptyset$ ≥ 0.7 ≤ 1.0	$\alpha_2 = 1.0$
Transverse pressure confinement	$\alpha_5 = 1 - 0.004p$ ≥ 0.7 ≤ 1.0	$\alpha_5 = 1.0$
Overlapping length	$\alpha_6 = (p_1 / 25)^{0.25}$ ≥ 1.0 ≤ 1.5	

Where:

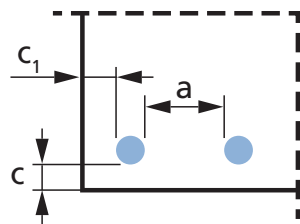

$c_d = \min (a/2, c_1, c)$

p : transverse pressure [MPa] in the ultimate limit state I_{bd}

p_1 is the percentage of the overlapped reinforcement bar within $0.65 \cdot l_0$ from the centre of the length of the overlap considered

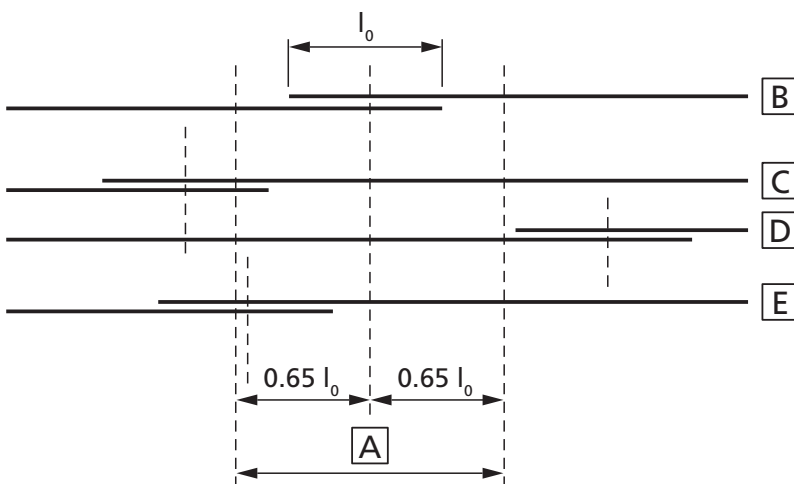

- A** Section considered
- B** Bar I
- C** Bar II
- D** Bar III
- E** Bar IV



MOPUR3

TABLES OF PRECALCULATED VALUES

Concrete class 20/25																		
Resistance to concrete compression [$f_{ck,cube}$]: 25 N/mm ²																		
Bar Ø	d_s	[mm]	Ø8	Ø10	Ø12	Ø14	Ø16	Ø20	Ø25	Ø28	Ø32							
Bar size	d_s	[mm]	8	10	12	14	16	20	25	28	32							
Cross-sectional area	A_s	[mm ²]	50.3	78.5	113.1	153.9	201.1	314.2	490.9	615.8	804.2							
Yield stress of the steel	f_{yd}	[kN]	500	500	500	500	500	500	500	500	500							
Safety factor	$\gamma_{M,s}$	[mm ²]	1.15	1.15	1.15	1.15	1.15	1.15	1.15	1.15	1.15							
Calculated steel resistance	$N_{Rd,s}$	[kN]	21.9	34.1	49.2	66.9	87.4	136.6	213.4	267.7	349.7							
Calculated bonding resistance	f_{bd}	[N/mm ²]	2.30	2.30	2.30	2.30	2.30	2.30	2.30	2.30	2.30							
Diameter of the drilled hole	d_h	[mm]	12	14	16	18	20	25	32	35	40							
Spacing between bars \geq	s	[mm]	50	50	60	70	80	100	125	140	160							
Distance from the edge (drilled using compressed air) \geq	c	[mm]	50 + 0.06 L_b															
Distance from the edge (drilled in percussion mode) \geq	c	[mm]	30 + 0.08 $L_b \geq 2\Phi$															
Anchor length, L_b [mm]			Calculated extraction resistance by bonding*, N_{Rd} [kN]															
113	6.5		Area not permitted															
142	8.2	10.3																
170	9.8	12.3										14.7						
198	11.4	14.3										17.2	20.0					
200	11.6	14.5										17.3	20.2					
210	12.1	15.2										18.2	21.2					
227	13.1	16.4										19.7	23.0	26.2				
240	13.9	17.3										20.8	24.3	27.7				
284	16.4	20.5										24.6	28.7	32.8	41.0			
300	17.3	21.7										26.0	30.3	34.7	43.4			
354	20.5	25.6										30.7	35.8	40.9	51.2	63.9		
375	21.7	27.1										32.5	37.9	43.4	54.2	67.7		
397	21.9	28.7										34.4	40.2	45.9	57.4	71.7	80.3	
400	21.9	28.9										34.7	40.5	46.2	57.8	72.3	80.9	
420		30.3										36.4	42.5	48.6	60.7	75.9	85.0	
454		32.8										39.4	45.9	52.5	65.6	82.0	91.9	105.0
480		34.1										41.6	48.6	55.5	69.4	86.7	97.1	111.0
500		34.1										43.4	50.6	57.8	72.3	90.3	101.2	115.6
600												49.2	60.7	69.4	86.7	108.4	121.4	138.7
700				66.9	80.9	101.2	126.4	141.6	161.9									
800					87.4	115.6	144.5	161.9	185.0									
1000						136.6	180.6	202.3	231.2									
Length for reaching the yield stress of the steel, $L_{b,Rd}$ [mm]		378	473	567	662	756	945	1,181	1,323	1,512								

Values shaded in blue are not valid for overlap bonds

* Values valid for ($\alpha_2=\alpha_5=\alpha_6=1$). In case of poor bonding conditions, multiply values by 0.7.



MOPUR3

TABLES OF PRECALCULATED VALUES

Concrete class 30/37												
Resistance to concrete compression [$f_{ck,cube}$]: 37 N/mm ²												
Bar Ø	d_s	[mm]	Ø8	Ø10	Ø12	Ø14	Ø16	Ø20	Ø25	Ø28	Ø32	
Bar size	d_s	[mm]	8	10	12	14	16	20	25	28	32	
Cross-sectional area	A_s	[mm ²]	50.3	78.5	113.1	153.9	201.1	314.2	490.9	615.8	804.2	
Yield stress of the steel	f_{yd}	[kN]	500	500	500	500	500	500	500	500	500	
Safety factor	$\gamma_{M,s}$	[mm ²]	1.15	1.15	1.15	1.15	1.15	1.15	1.15	1.15	1.15	
Calculated steel resistance	$N_{rd,s}$	[kN]	21.9	34.1	49.2	66.9	87.4	136.6	213.4	267.7	349.7	
Calculated bonding resistance	f_{bd}	[N/mm ²]	3.00	3.00	3.00	3.00	3.00	3.00	3.00	3.00	2.70	
Diameter of the drilled hole	d_h	[mm]	12	14	16	18	20	25	32	35	40	
Spacing between bars \geq	s	[mm]	50	50	60	70	80	100	125	140	160	
Distance from the edge (drilled using compressed air) \geq	c	[mm]	50 + 0.06 L_b									
Distance from the edge (drilled in percussion mode) \geq	c	[mm]	30 + 0.08 $L_b \geq 2\Phi$									
Anchor length, L_b [mm]			Calculated extraction resistance by bonding*, N_{Rd} [kN]									
113	8.5											
142	10.7	13.4										
170	12.8	16.0	19.2									
198	14.9	18.7	22.4	26.1								
200	15.1	18.8	22.6	26.4								
210	15.8	19.8	23.8	27.7								
227	17.1	21.4	25.7	30.0	34.2							
240	18.1	22.6	27.1	31.7	36.2							
284	21.4	26.8	32.1	37.5	42.8	53.5						
300	21.9	28.3	33.9	39.6	45.2	56.5						
354	21.9	33.4	40.0	46.7	53.4	66.7	83.4					
375	21.9	34.1	42.4	49.5	56.5	70.7	88.4					
397	21.9	34.1	44.9	52.4	59.9	74.8	93.5	104.8				
400	21.9	34.1	45.2	52.8	60.3	75.4	94.2	105.6				
420		34.1	47.5	55.4	63.3	79.2	99.0	110.8				
454		34.1	49.2	59.9	68.5	85.6	107.0	119.8	136.9			
480		34.1	49.2	63.3	72.4	90.5	113.1	126.7	144.8			
500		34.1	49.2	66.0	75.4	94.2	117.8	131.9	150.8			
600			49.2	66.9	87.4	113.1	141.4	158.3	181.0			
700				66.9	87.4	131.9	164.9	184.7	164.9			
800					87.4	136.6	188.5	211.1	188.5			
1000						136.6	213.4	263.9	301.6			
Length for reaching the yield stress of the steel, $L_{b,rd}$ [mm]	290	362	435	507	580	725	906	1,014	1,288			

Values shaded in blue are not valid for overlap bonds

* Values valid for ($\alpha_2 = \alpha_5 = \alpha_6 = 1$). In case of poor bonding conditions, multiply values by 0.7.



MOPUR3

TABLES OF PRECALCULATED VALUES

Concrete class 40/50												
Resistance to concrete compression [$f_{ck,cube}$]: 50 N/mm ²												
Bar Ø	d_s	[mm]	Ø8	Ø10	Ø12	Ø14	Ø16	Ø20	Ø25	Ø28	Ø32	
Bar size	d_s	[mm]	8	10	12	14	16	20	25	28	32	
Cross-sectional area	A_s	[mm ²]	50.3	78.5	113.1	153.9	201.1	314.2	490.9	615.8	804.2	
Yield stress of the steel	f_{yd}	[kN]	500	500	500	500	500	500	500	500	500	
Safety factor	$\gamma_{M,s}$	[mm ²]	1.15	1.15	1.15	1.15	1.15	1.15	1.15	1.15	1.15	
Calculated steel resistance	$N_{Rd,s}$	[kN]	21.9	34.1	49.2	66.9	87.4	136.6	213.4	267.7	349.7	
Calculated bonding resistance	f_{bd}	[N/mm ²]	3.70	3.70	3.70	3.70	3.70	3.70	3.70	3.70	2.70	
Diameter of the drilled hole	d_h	[mm]	12	14	16	18	20	25	32	35	40	
Spacing between bars \geq	s	[mm]	50	50	60	70	80	100	125	140	160	
Distance from the edge (drilled using compressed air) \geq	c	[mm]	50 + 0.06 L_b									
Distance from the edge (drilled in percussion mode) \geq	c	[mm]	30 + 0.08 $L_b \geq 2\Phi$									
Anchor length, L_b [mm]			Calculated extraction resistance by bonding*, N_{Rd} [kN]									
113	10.5											
142	13.2	16.5										
170	15.8	19.8	23.7									
198	18.4	23.0	27.6	32.2								
200	18.6	23.2	27.9	32.5								
210	19.5	24.4	29.3	34.2								
227	21.1	26.4	31.7	36.9	42.2							
240	21.9	27.9	33.5	39.1	44.6							
284	21.9	33.0	39.6	46.2	52.8	66.0						
300	21.9	34.1	41.8	48.8	55.8	69.7						
354	21.9	34.1	49.2	57.6	65.8	82.3	102.9					
375	21.9	34.1	49.2	61.0	69.7	87.2	109.0					
397	21.9	34.1	49.2	64.6	73.8	92.3	115.4	129.2				
400	21.9	34.1	49.2	65.1	74.4	93.0	116.2	130.2				
420		34.1	49.2	66.9	78.1	97.6	122.1	136.7				
454		34.1	49.2	66.9	84.4	105.5	131.9	147.8	168.9			
480		34.1	49.2	66.9	87.4	111.6	139.5	156.2	178.5			
500		34.1	49.2	66.9	87.4	116.2	145.3	162.7	186.0			
600			49.2	66.9	87.4	136.6	174.4	195.3	223.2			
700				66.9	87.4	136.6	203.4	227.8	260.4			
800		Yield stress area of the bar				87.4	136.6	213.4	260.4	297.6		
1000						136.6	213.4	267.7	349.7			
Length for reaching the yield stress of the steel, $L_{b,Rd}$ [mm]			235	294	352	411	470	587	734	822	940	

Values shaded in blue are not valid for overlap bonds

* Values valid for ($\alpha_2 = \alpha_5 = \alpha_6 = 1$). In case of poor bonding conditions, multiply values by 0.7.



MOPUR3

TABLES OF PRECALCULATED VALUES

Concrete class 50/60												
Resistance to concrete compression [$f_{ck,cube}$]: 60 N/mm ²												
Bar Ø	d_s	[mm]	Ø8	Ø10	Ø12	Ø14	Ø16	Ø20	Ø25	Ø28	Ø32	
Bar size	d_s	[mm]	8	10	12	14	16	20	25	28	32	
Cross-sectional area	A_s	[mm ²]	50.3	78.5	113.1	153.9	201.1	314.2	490.9	615.8	804.2	
Yield stress of the steel	f_{yd}	[kN]	500	500	500	500	500	500	500	500	500	
Safety factor	$\gamma_{M,s}$	[mm ²]	1.15	1.15	1.15	1.15	1.15	1.15	1.15	1.15	1.15	
Calculated steel resistance	$N_{Rd,s}$	[kN]	21.9	34.1	49.2	66.9	87.4	136.6	213.4	267.7	349.7	
Calculated bonding resistance	f_{bd}	[N/mm ²]	4.00	4.00	4.00	4.00	4.00	4.00	4.00	3.70	2.70	
Diameter of the drilled hole	d_h	[mm]	12	14	16	18	20	25	32	35	40	
Spacing between bars \geq	s	[mm]	50	50	60	70	80	100	125	140	160	
Distance from the edge (drilled using compressed air) \geq	c	[mm]	50 + 0.06 L_b									
Distance from the edge (drilled in percussion mode) \geq	c	[mm]	30 + 0.08 $L_b \geq 2\Phi$									
Anchor length, L_b [mm]			Calculated extraction resistance by bonding*, N_{Rd} [kN]									
113	12.2											
142	15.3	19.2										
170	18.4	23.0	27.6									
198	21.4	26.7	32.1	37.4								
200	21.6	27.0	32.4	37.8								
210	21.9	28.4	34.0	39.7								
227	21.9	30.7	36.8	42.9	49.1							
240	21.9	32.4	38.9	45.4	51.9							
284	21.9	34.1	46.0	53.7	61.4	76.7						
300	21.9	34.1	48.6	56.7	64.8	81.1						
354	21.9	34.1	49.2	66.9	76.5	95.6	119.6					
375	21.9	34.1	49.2	66.9	81.1	101.3	126.6					
397	21.9	34.1	49.2	66.9	85.8	107.3	134.1	150.2				
400	21.9	34.1	49.2	66.9	86.5	108.1	135.1	151.3				
420		34.1	49.2	66.9	87.4	113.5	141.8	158.9				
454		34.1	49.2	66.9	87.4	122.7	153.3	171.7	168.9			
480		34.1	49.2	66.9	87.4	129.7	162.1	181.6	178.5			
500		34.1	49.2	66.9	87.4	135.1	168.9	189.1	186.0			
600			49.2	66.9	87.4	136.6	202.6	226.9	223.2			
700				66.9	87.4	136.6	213.4	264.8	260.4			
800			Yield stress area of the bar			87.4	136.6	213.4	267.7	297.6		
1000						136.6	213.4	267.7	349.7			
Length for reaching the yield stress of the steel, $L_{b,Rd}$ [mm]			202	253	303	354	404	505	632	708	940	

Values shaded in blue are not valid for overlap bonds

* Values valid for ($\alpha_2 = \alpha_5 = \alpha_6 = 1$). In case of poor bonding conditions, multiply values by 0.7.



MOPUR3

RANGE

PURE EPOXY 3:1



OPTION 1



385 ml

585 ml



CODE	DIMENSION	
NORMAL		
MOPUR3385	385 ml	12
MOPUR3585	585 ml	12

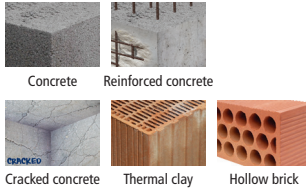

Accessories for chemical anchor cartridges

MO-PIS Application guns



MOPISP3385



MOPISP3585

CODE	MODEL
MOPISP3385	Manual 385 ml
MOPISP3585	Manual 585 ml

MO-AC Mixing tubes and miscellaneous



MORCEPKIT
Kit 3 brushes (ø15, ø20, ø30)



MORCANU

MORBOMBA

CODE	MODEL
MORBOMBA	Blower pump
MORCANU	Tube 170 - 300 - 410 ml
MORCEPKIT	Kit 3 brushes



Stud for chemical anchor with nut and washer

EQ-AC Zinc-plated



CODE	DIMENSION
EQAC08110	M8 x 110
EQAC10130	M10 x 130
EQAC12160	M12 x 160
EQAC16190	M16 x 190
EQAC20260	M20 x 260
EQAC24300	M24 x 300
EQAC30330	M30 x 330

EQ-A2 Stainless steel A2



CODE	DIMENSION
EQA208110	M8 x 110
EQA210130	M10 x 130
EQA212160	M12 x 160
EQA216190	M16 x 190
EQA220260	M20 x 260
EQA224300	M24 x 300
EQA230330	M30 x 330

EQ-A4 Stainless steel A4

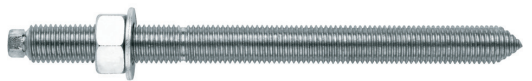

CODE	DIMENSION
EQA408110	M8 x 110
EQA410130	M10 x 130
EQA412160	M12 x 160
EQA416190	M16 x 190
EQA420260	M20 x 260
EQA424300	M24 x 300
EQA430330	M30 x 330